

Installation Note

**Agilent Technologies ESA E-Series Spectrum Analyzers
Noise Source Driver Assembly
(Part of Noise Figure Measurement Personality and Hardware,
Option 219)**



Part Number E4401-90463
Printed in USA December 2003



E4401-90463

Notice.

The information contained in this document is subject to change without notice.

Agilent Technologies makes no warranty of any kind with regard to this material, including but not limited to, the implied warranties of merchantability and fitness for a particular purpose. Agilent Technologies shall not be liable for errors contained herein or for incidental or consequential damages in connection with the furnishing, performance, or use of this material.

Microsoft® is a U.S. registered trademark of Microsoft Corp.

Introduction

This procedure can be used to retrofit the A7A13 Noise Source Driver Assembly, part of Option 219, into an E4401B, E4402B, E4404B, E4405B, or E4407B spectrum analyzer.

Products Affected:	E4401B E4402B E4404B E4405B E4407B
Serial Numbers:	US00000000/US99999999 MY00000000/MY99999999
Options:	part of Option 219
To Be Performed By:	(X) Agilent Technologies Service Center (X) Personnel Qualified by Agilent (X) Customer
Estimated Installation Time:	0.5 Hours
Estimated Verification Time:	0.5 Hours

Installation Kit Parts Lists

Option 219, Noise Figure Measurement Personality and Hardware

Quantity	Description	Part Number
1	Board Assembly, Noise Source Driver	E4401-60123
1	Noise Figure Measurement Personality Documentation Set	-----
1	Power Sensor cable	8120-8319
1	BNC cable	8120-1840
1	Installation Note	this note
1	Option Upgrade Entitlement Certificate	-----

Tools Required

- T-8 TORX screwdriver
- T-10 TORX screwdriver
- T-15 TORX screwdriver
- Voltmeter
- BNC (f) to dual banana plug adapter
- BNC cable

Torque Settings

To avoid potential RFI leakage and prevent connector damage, tighten screws and RF coax cable connectors to the following torque limits:

Item	Torque
SMA Connector	95 N-cm (8.5 in-lb)
SMC Connector	62 N-cm (5.5 in-lb)
3-mm, T-8 TORX screws	101 N-cm (9 in-lb)
3.5-mm, T-10 TORX screws	157 N-cm (14 in-lb)
4-mm, T-15 TORX screws	236 N-cm (21 in-lb)
Pozidrive Screws	157 N-cm (14 in-lb)

Procedure

Firmware Revision and Memory Size Verification

1. Turn on the analyzer and wait for the power-on alignments to complete. Check that there are no error messages displayed.
2. Press **System, More, Show System**. Make note of the firmware revision and see if Option B72, Expansion Memory, is listed on the display.
3. If the firmware revision is A.12.00 or later, the firmware does not need to be upgraded and you can skip the remaining steps and go to the section “[Outer Cover Removal](#)” below.
4. If the firmware revision is A.11.00 or earlier and Option B72 *is* installed, you will need to upgrade the analyzer firmware to the latest version using one of the following methods:
 - a. Download the instrument firmware via the world-wide web at http://www.agilent.com/find/esa_firmware. This entire process of upgrading firmware will take approximately 45 minutes.
 - b. Receive the latest firmware upgrade disk set by ordering upgrade Option UE2.
5. If the firmware revision is A.11.00 or earlier and Option B72 *is not* installed, you will need to order upgrade Option B72. The Option B72 upgrade kit includes the latest analyzer firmware.

WARNING **Before you disassemble the instrument, turn the power switch OFF and unplug the instrument. Failure to unplug the instrument can result in personal injury.**

CAUTION Electrostatic discharge (ESD) can damage or destroy electronic components. All work on electronic assemblies should be performed at a static-safe workstation. Refer to the documentation that pertains to your instrument for information about static-safe workstations and ordering static-safe accessories.

Outer Cover Removal

1. Refer to [Figure 1](#). Disconnect the spectrum analyzer from ac power (1).
2. Remove any adapters or cables (2) connected to the front frame.
3. Carefully place the analyzer on the work surface with the front frame (3) facing down.
4. Position the handle (4) as shown.
5. Remove the four screws (5) that hold the rear frame and outer case in place.
6. Remove the rear frame (6).
7. Pull the outer cover (7) off towards the rear of the instrument.

Inner Shield Removal

1. Lay the instrument flat as shown in [Figure 2](#).
2. Remove the 15 screws (2) and (3) attaching the inner shield to the chassis. Note that the number of screws attaching the inner shield may vary with option mixes.
3. Remove the inner shield (1) from the chassis.

Figure 2 Inner Shield Removal

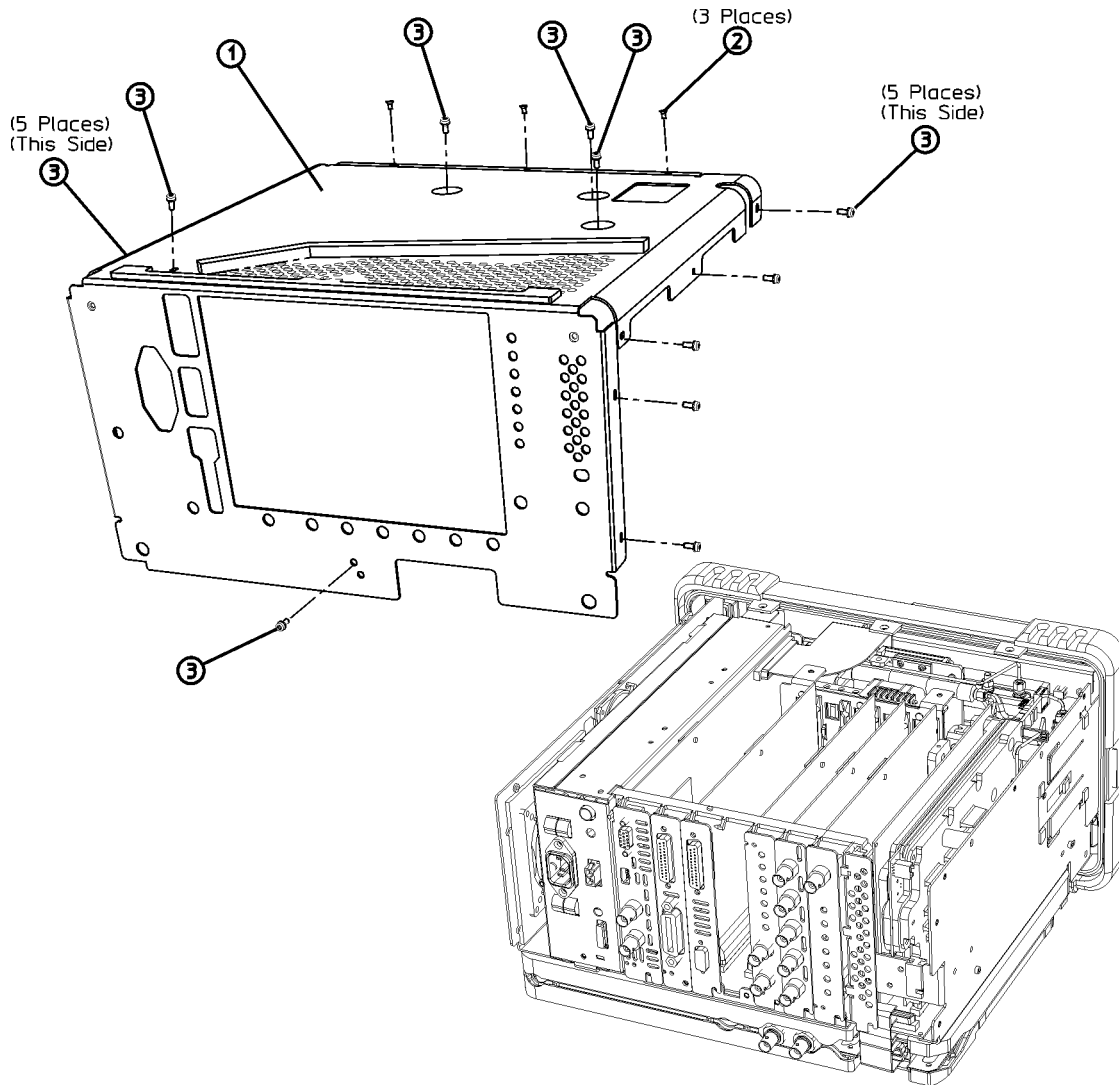

dl72b

Installing the Option

1. Refer to [Figure 3](#). Loosen, but do not remove, all 9 of the screws (1) securing the boards and blank plates at the rear of the chassis.
2. Refer to [Figure 4](#). Remove the vibration support bar (1) at the top rear of the instrument by pressing in the locking tabs (2) and rotating the bar upward. The bar can be removed by sliding it out of the holes in each assembly.

Figure 3 Instrument, Rear View

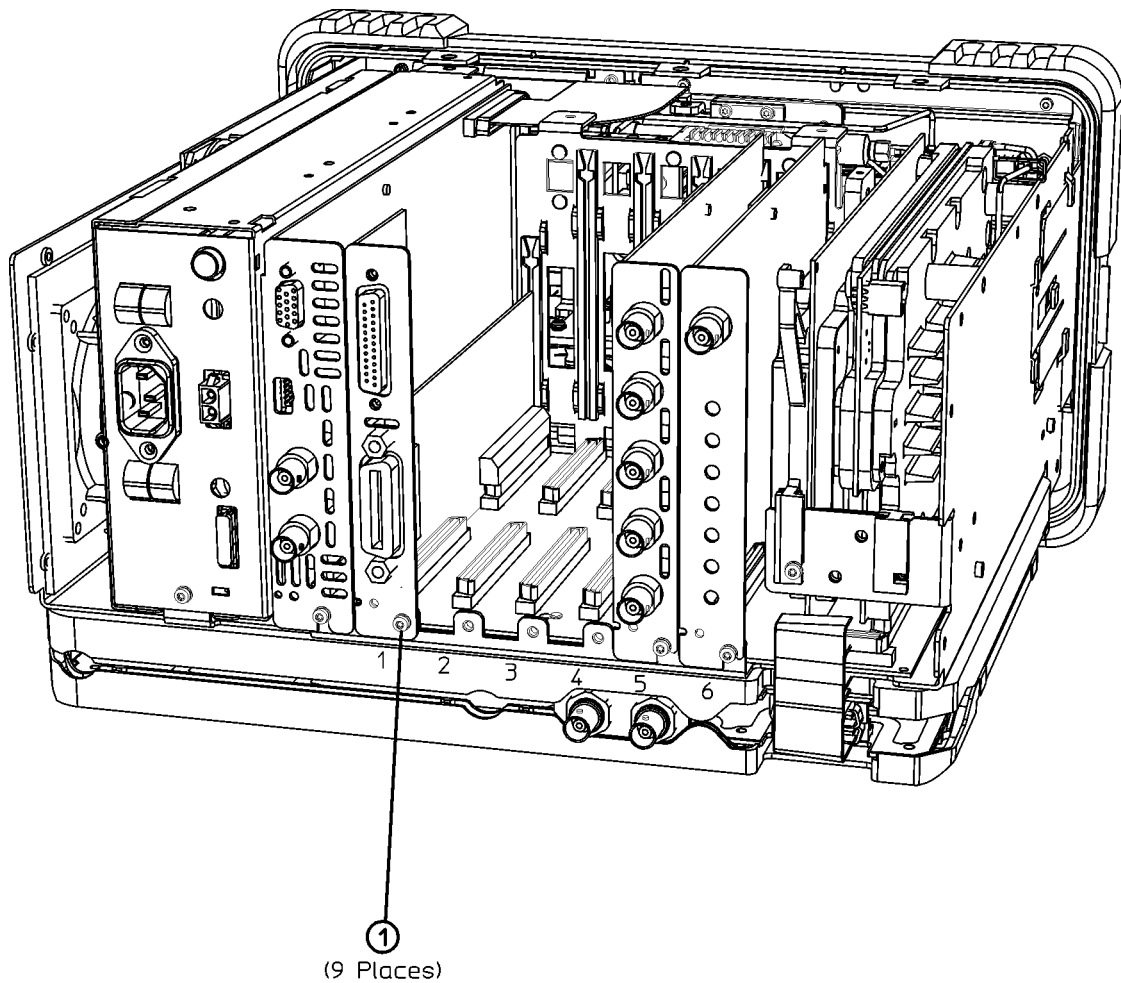

dl79b

CAUTION The vibration support bar can easily be broken if it is forced.
Remove it with care.

Figure 4 Removing the Vibration Support

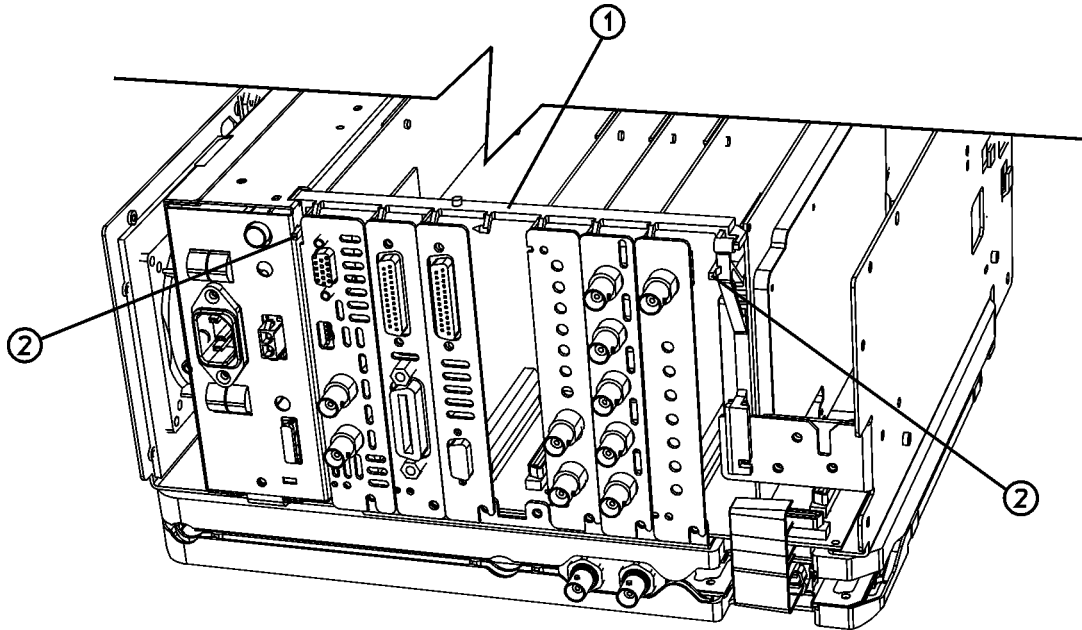

d178b

3. The preferred slot for the A7A13 Noise Source Driver Assembly is slot 3. However, it can be inserted in either slot 1, 2, 3, or 4 if a shielded assembly, such as Option 120 or Option B7E, is not installed in the next higher-numbered slot.
4. Remove the single screw (1) securing the assembly or blank panel to the chassis in the slot where A7A13 will be installed.
5. Carefully pull up on the blank panel or assembly, to remove it from the analyzer.
6. Carefully plug the A7A13 into the desired empty slot.
7. Replace the screw (1) that secures the assembly being installed, but do not tighten it yet.

8. Refer to [Figure 5](#). Replace the vibration support bar (1) as follows:
 - a. Position the vibration support bar (1) as shown and insert the hook (2) into the IF's support arm.
 - b. Engage each hook (3) of the other assemblies or blanks in turn.
 - c. As you position each of the assemblies or blanks, rotate (4) the support bar to lock each one in place.
 - d. Refer to [Figure 6](#). Make sure that the tab (1) is positioned in the slot of the power supply chassis and the vibration bar is fully seated and locked (2) into position.

CAUTION The vibration support bar can easily be broken if it is forced. Install it with care.

Figure 5 Installing the Vibration Support Bar

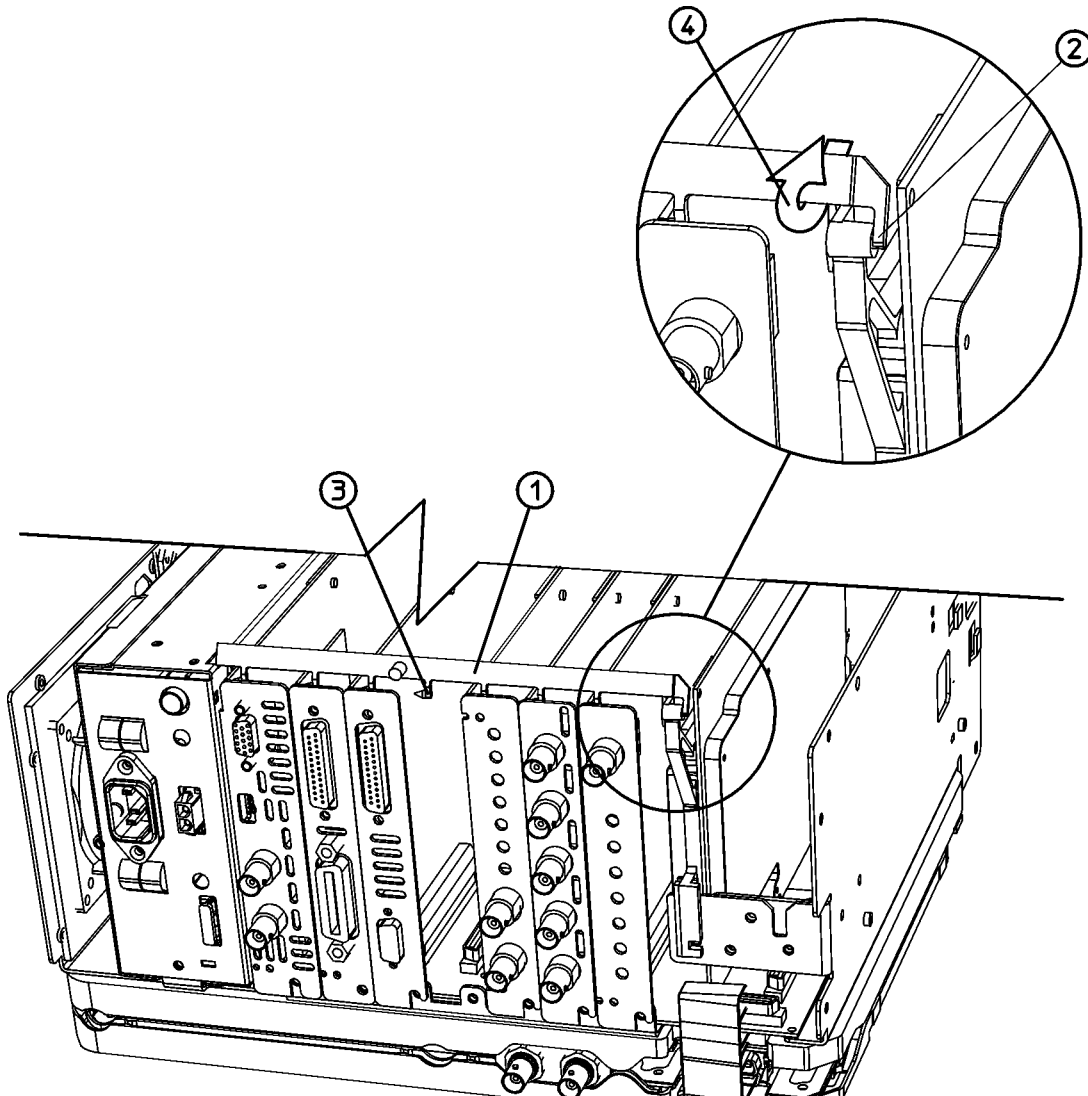
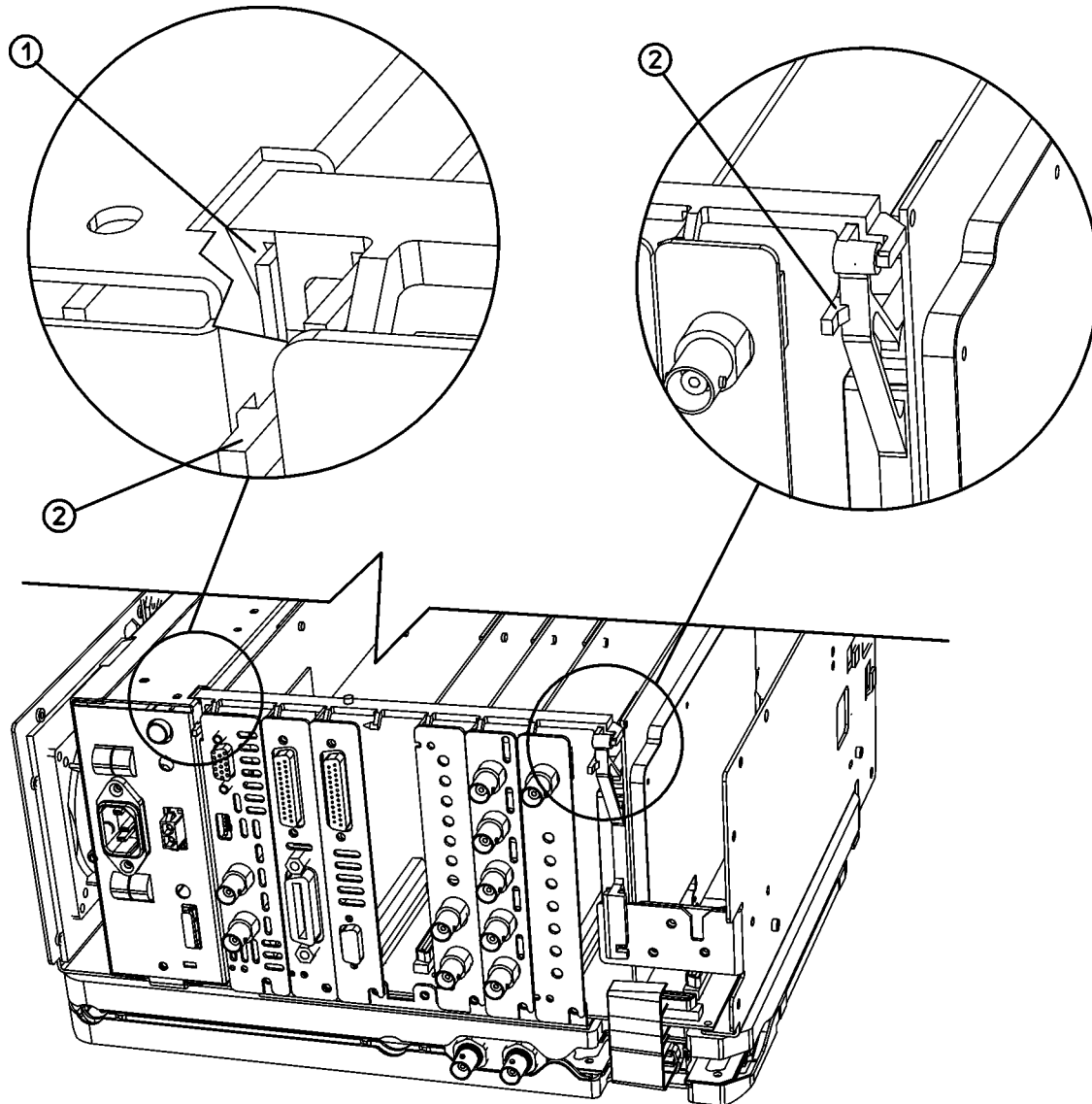

Figure 6 Seating the Vibration Support Bar



d173b

9. Tighten all the screws that were loosened in the removal procedure to 101 N-cm (9 in-lb).
10. Refer to [Figure 2](#). Carefully position the inner shield (1) on the instrument.
11. Replace the screws (2) and (3), and tighten them to 101 N-cm (9 in-lb).
12. Carefully place the spectrum analyzer on the work surface with the front frame facing down.
13. Replace the instrument outer cover aligning the grill on the side of the case to the fan on the A5 power supply assembly.
14. Fit the leading edge of the case completely into the slot on the back of the front frame assembly.

15. Refer to [Figure 1](#). Replace the rear frame assembly (6) using the four screws (5) to fasten the rear frame to the instrument. Tighten the screws to 236 N-cm (21 in-lb).
16. Refer to the calibration guide for the instrument being upgraded and perform the following performance verification tests:
 - Displayed Average Noise Level
 - Residual Responses

Install the Firmware and Personality

1. If the current firmware revision is A.11.00 or earlier, upgrade the firmware to the latest revision.
2. Install the Noise Figure Measurement Personality as described in the Noise Figure Measurement Personality Guide.
3. The entitlement certificate supplied in this kit allows you to obtain a license key from our Agilent website so you can enable this personality. Once you have retrieved the license key, you can begin the process of activating the personality as described in the Noise Figure Measurement Personality Guide.

Functional Testing

1. Connect the voltmeter to the +28 V PULSED output on the analyzer rear panel using a BNC cable and a BNC to dual banana plug adapter.
2. Set the voltmeter to read dc voltages from 0 to 30 V.
3. On the analyzer, press **MODE**, **Noise Figure** to start the noise figure personality.
4. Press **MEASURE**, **Monitor Spectrum**.
5. Press **Source**, and toggle **Noise Source** so that “On” is underlined. Verify that the voltmeter reads $28V \pm 0.1 V$.
6. Press **Source**, and toggle **Noise Source** so that “Off” is underlined. Verify that the voltmeter reads less than 1 V.